



FUN4FOUR

MINI

Manual

English

Thank you for choosing

Fun4Four Mini

To gain satisfactory use from your **Fun4Four Mini** terminal, please read the manual thoroughly. Please store this manual in such a way as to have it readily at hand if so required.

WARNING:

This is a Class A product – see [EC Declaration of Conformity](#). In a domestic environment this product may cause radio interference in which case the user may be required to take adequate measures.

For additional help please contact our service line

+43 (0)7229/78040-250 or hotline@tab.at

Additional information and downloads at:

<https://www.tab.at> in the download section

Fun4Four MINI is a trademark of TAB Austria, ©1962-2023.

All Rights Reserved - including any arisings from photomechanical reproduction and storage in electronic or any other medium, the system, cabinet, handbook and all components are subject to international copyright regulations.

All illustrations and descriptions within this manual are carefully considered, however, mistakes cannot be completely ruled out. The manufacturer doesn't accept legal responsibility of liability in any form of regard to errors in detail or any consequences that may arise from such problems. If you face any problems, please get in contact with us.

Table of content

TABLE OF CONTENT	3
SETUP POINTERS	5
Safety regulations for the user.....	5
ADDITIONAL INFORMATION	7
Definition of the key districts	7
DESCRIPTION	7
General.....	7
Operating equipment	7
PC-SYSTEM COMPONENTS	7
Standard equipment	7
TECHNICAL DATA	8
Machine dimensions.....	8
Electronic Data Fun4Four Mini	9
Component Data Fun4Four Mini	9
SETUP AND CONNECTIONS	9
TEST MODE	10
Menu General.....	11
Menu Basic Settings.....	13
Menu Machine Test.....	14
Menu Hardware Settings	15
Menu Bookkeeping.....	17
Menu Game Price Settings.....	19
Menu Games.....	20
Menu PIN Settings.....	21
SUPERVISOR TESTMODE.....	22
Menu ChampionsNet.....	23
Menu Online Terminal Management (OTM)	26
PROGRAM UPDATE	29
Procedure	29
TROUBLESHOOTING	30

MAINTENANCE OPERATING ELEMENTS.....	32
Coin Acceptor	32
COMESTERO RM5HD	32
NRI G-13 MFT.....	34
Bill Acceptor.....	35
ASTRO GBA ST2	35
WIRING DIAGRAM MAIN HARNESS.....	39
BLOCK DIAGRAM POWER CABLES.....	40
EXPLODED ASSEMBLY DRAWINGS	41
Exploded Drawing Fun4Four Evo.....	41
Assembly Cash Section.....	42
Assembly PC Section	43
Assembly Table Section F4F Evo.....	44
Assembly Deposit Section Drawing.....	46
EC DECLARATION OF CONFORMITY.....	47
SPECIAL BUSINESS TERMS OTM.....	48
END USER LICENSE AGREEMENT FOR MICROSOFT SOFTWARE.....	50
SOFTWARE LICENSE	50
WARRANTY TERMS	54
NOTES	57

Setup Pointers

Safety regulations for the user

The machine should only be operated in a dry room and connected to a safety plug socket that complies with the relevant safety standards.

- Before starting the machine, it should be allowed to attain room temperature.
- Check the main voltage before connecting the machine!
- The machine is designed for an alternating voltage of 230 Volts (*or 115 Volts if specified on the type plate*), 50 Hz (*or 60 Hz*) and 180 W.
- The machine may only be operated with two 4 ampere fuses.
- In case of damage to housing parts, protruding wires, machine fires or smashed LCD/Touch screen module, the machine must be immediately switched off and the main plug disconnected.
- Defective or bare wire cables, especially power cables and plug connectors must be replaced.

ATTENTION:

In such cases ensure that any machine contact is avoided and that it cannot be switched on!

- The recommended ambient temperature is 5 – 35 degrees Celsius.
- The recommended working temperature is 15 – 40 degrees Celsius.
- The recommended absolute humidity is between 30% and 75% RH, not condensed.
- When positioned alongside other machines, interference in normal operation may occur.
- Every machine is factory tested and delivered in a preset condition.

Please pay attention to the [licensing terms and conditions of Microsoft!](#)



Disposal of Old Electrical & Electronic Equipment (Applicable in the European Union and other European countries with separate collection systems)

This symbol on the product or on its packaging indicates that this product shall not be treated as household waste. Instead it shall be handed over to the applicable collection point for the recycling of electrical and electronic equipment. By ensuring this product is disposed of correctly, you will help prevent potential negative consequences for the environment and human health, which could otherwise be caused by inappropriate waste handling of this product. The recycling of materials will help to conserve natural resources. For more detailed information about recycling of this product, please contact your local city office, your household waste disposal service or the company where you purchased the product.

ATTENTION:

**When you work on the machine, you must turn off the machine and plug out the voltage.
Repairing activities on the machine only from qualified personal!**

In the inside of the machine there is a sticker (see below). Please inform the qualified personal before he begins to work.



Additional Information

Definition of the key districts

KEY	DISTRICT	EXPLOYEE
Yellow	PC / hardware components	Service engineer
Black	Hardware components	Service engineer
Blue	Cash boxes	Cashier

Description

General

The **Fun4Four Mini** is an ergonomically designed entertainment machine.

The machine contains...

- 1x electronic coin acceptor (optional)
- 1x electronic banknote acceptor (optional)
- 1x cashless payment system (optional)
- 1x 32" LED display with touch screen
- 1x complete industrial PC system

Operating equipment

All games on the **Fun4Four Evo / Evo S** will be played with the touch screen.

PC-System components

Standard equipment

- PC-System with a AMD APU + 8 GB memory
- On-Board graphic card (1920 x 1080 resolution, FULL HD)
- Minimum 250 GB SATA hard disk drive or minimum 120 GB SSD
- TAB I/O interface card with safety-memory

Technical Data

Machine dimensions

	unpacked	packed
Depth	53,9 cm	59 cm*
Width	83,4 cm	90 cm
Height	77,5 cm	91 cm
Weight	80 kg*	89 kg*

*Depends on machine configuration

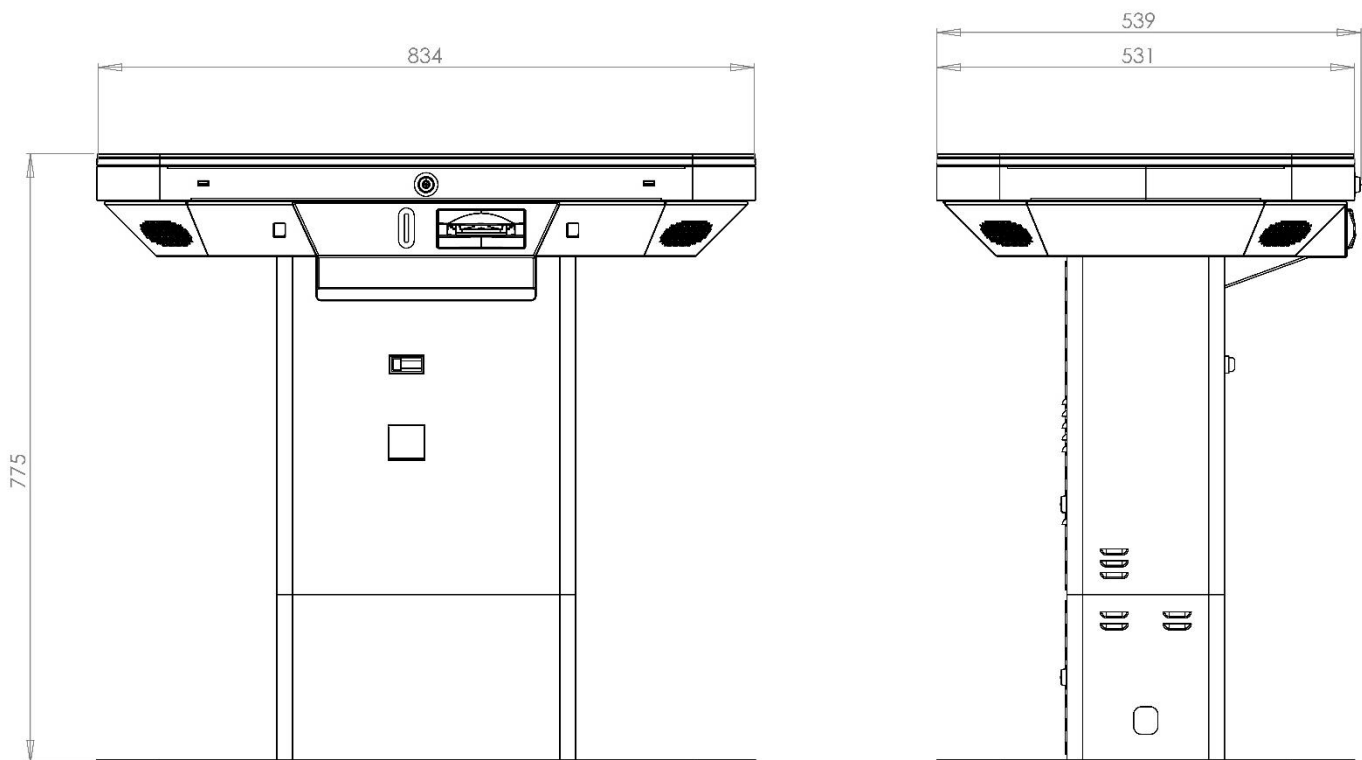

Electronic Data Fun4Four Mini

Electricity: 115-230 VAC / 50-60 Hz

Performance: 180 Watts

Cutout: 2x 4 Ampere

ATTENTION:

When you have more than one machine on a voltage splitter please note:
With a normal installed electricity port with a cutout from 16 Ampere do not plug in more than 3 machines.

Component Data Fun4Four Mini

- 32" Multi touch screen
 - 32" LED display
- Resolution: 1920 x 1080 Full HD

Setup and connections

- Unpacking the machine
- Before starting the machine, it should be allowed to attain room temperature.
- Every machine is factory tested and delivered in a preset condition.
- Connect to power 230 V / 50 Hz (power socket)
- Connection of network
 - Choice of:
 - Network cable directly connected to PC
 - WLAN Adapter linked to the PC and then start the WLAN configuration ("Menu ChampionsNet")

At the bottom respectively on the side of the "Fun4Four Mini" there is a hole to insert the network-/power cable.

Test mode

Push button for **test mode** in the inside of the machine

You will get in this menu:



Menu General

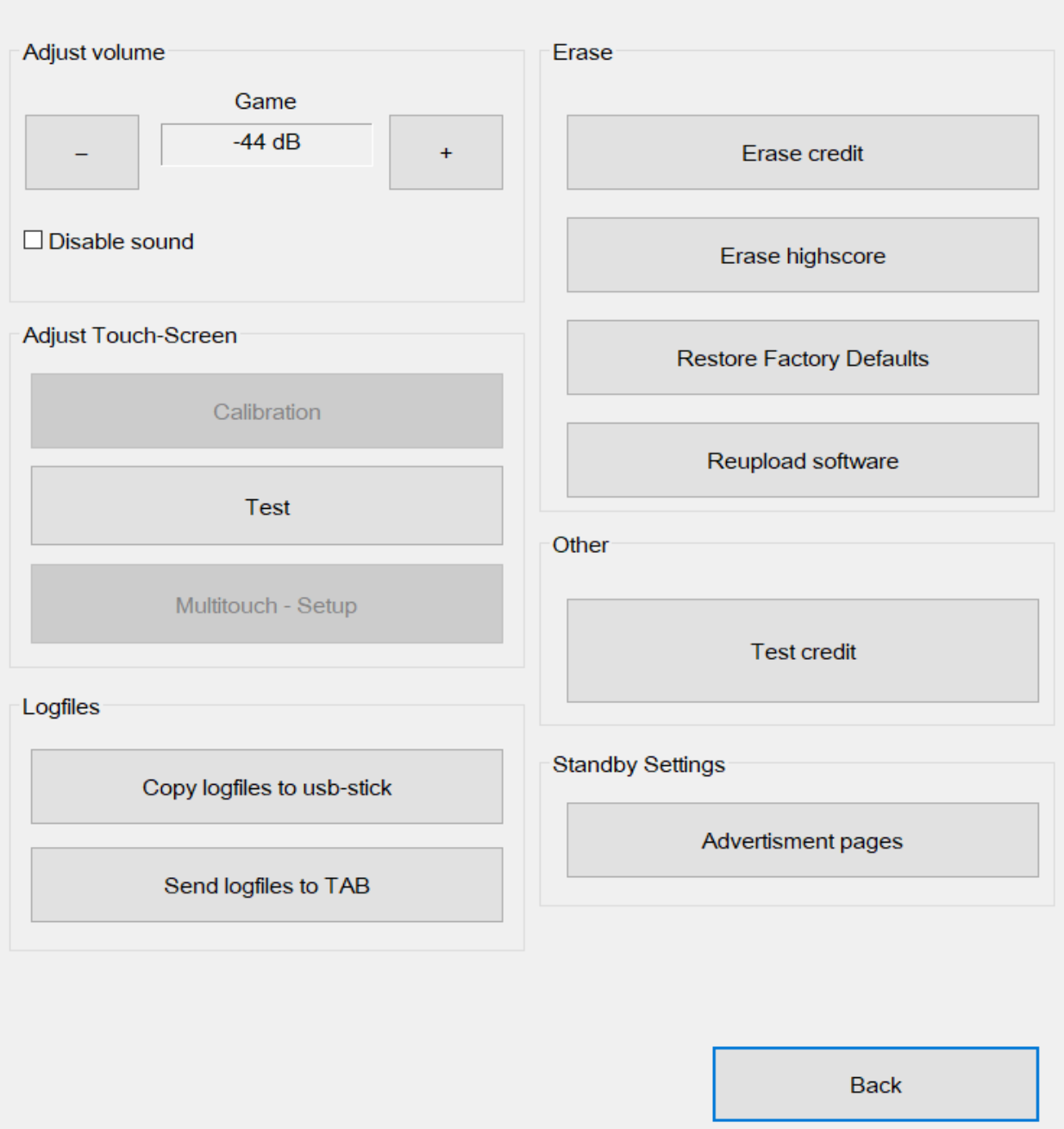

Adjust volume

Game

-44 dB

- +

Disable sound

Adjust Touch-Screen

Calibration

Test

Multitouch - Setup

Logfiles

Copy logfiles to usb-stick

Send logfiles to TAB

Erase

Erase credit

Erase highscore

Restore Factory Defaults

Reupload software

Other

Test credit

Standby Settings

Advertisement pages

Back

- Adjust volume
- Adjust touch screen
 - Test

HINT:

If your touch screen does not work anymore, just press the test mode button for 5 seconds in the main menu of the test mode. Afterwards a new installation of the touch screen will be started.

- **Logfiles**
 - Copy logfiles to USB-stick
 - Send logfiles to_TAB
- **Delete**
 - Erase credits
 - Delete high score
 - Master Reset
This option will set the machine back to factory settings.
All data will be lost.
- **Other**
 - Test credit
Set test-credits.
- **Standby Settings**
 - Advertisement pages
Here you can change the duration of advertisement pages being shown.

Standby Settings

Start delay for commercial pages

-60 -5 0.0 s +5 +60

Time between commercial pages

-1 -0.5 4.0 s +0.5 +1

Delete all local commercial pages

Menu Basic Settings

Date and time

Time Date Time

Zone GMT +02:00

Enable Automatic Daylight Saving Time

Zone +1h
Zone -1h
Zone +30m
Zone -30m

Basic language

English ▼

Highscore

Highscore system is enabled

Automatically delete high score

never

Every Sunday ▼ after - 4 + week(s)

at - 08:00 + (only 30 minute steps possible)

individually for each entry

Apply
Back

- **Date and time**

HINT:

A machine, which is active in the ChampionsNet, will set the date and the time automatically. You only need to set the correct time zone.

- **Basic language**

Here you can decide the language the machine is starting with.

- **Automatically delete high score**

Here you can decide if local high score lists will be deleted never, to a specific time or after a period of time. If the checkbox "individually for each entry" is activated, each entry will be deleted separately after the chosen time period. If it is deactivated, all high score lists will be deleted after the chosen time period.

Menu Machine Test

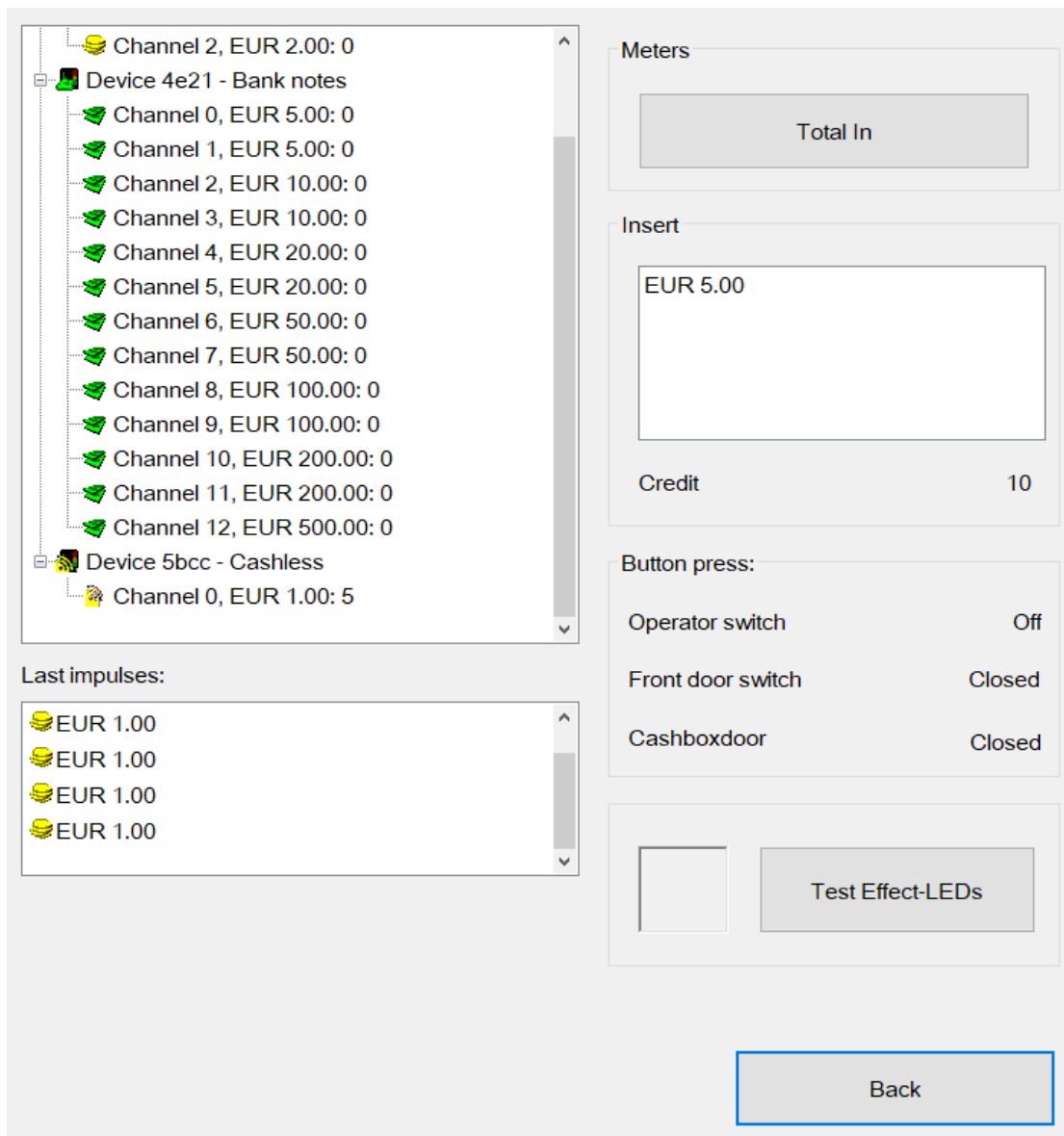

The screenshot displays the 'Menu Machine Test' interface. On the left, a tree view shows the following structure:

- Channel 2, EUR 2.00: 0
- Device 4e21 - Bank notes
 - Channel 0, EUR 5.00: 0
 - Channel 1, EUR 5.00: 0
 - Channel 2, EUR 10.00: 0
 - Channel 3, EUR 10.00: 0
 - Channel 4, EUR 20.00: 0
 - Channel 5, EUR 20.00: 0
 - Channel 6, EUR 50.00: 0
 - Channel 7, EUR 50.00: 0
 - Channel 8, EUR 100.00: 0
 - Channel 9, EUR 100.00: 0
 - Channel 10, EUR 200.00: 0
 - Channel 11, EUR 200.00: 0
 - Channel 12, EUR 500.00: 0
- Device 5bcc - Cashless
 - Channel 0, EUR 1.00: 5

Below the tree view, the 'Last impulses:' section shows a list of four entries, each with a coin icon and the text 'EUR 1.00'.

On the right side, the 'Meters' section contains a 'Total In' button. The 'Insert' section features a text input field with 'EUR 5.00' and a 'Credit' counter showing '10'. The 'Button press:' section includes three rows: 'Operator switch' (Off), 'Front door switch' (Closed), and 'Cashboxdoor' (Closed). At the bottom right, there is a 'Test Effect-LEDs' button and a 'Back' button.

In this menu you can test your coin mech and banknote reader.



















Just throw in a coin or insert a note, which you want to test. The counter will be increased by 1 afterwards.

You can also check function of door switches and LED effects of the LED ring in the table section.

- **Total In**
After you press this button, the counter will be increased by 10.
- **Test Effect-LEDs**
- **Cashless payment device**
Show activated cashless payment device

ATTENTION: As soon as you are operating a registered cashless payment system, a free-of-charge device test (Testmode – Machine tests) is **NO** longer available.

Menu Hardware Settings

-  Device 4e20 - Coins
 -  Channel 0, EUR 0.50
 -  Channel 1, EUR 1.00
 -  Channel 2, EUR 2.00
-  Device 4e21 - Bank notes
 -  Channel 0, EUR 5.00
 -  Channel 1, EUR 5.00
 -  Channel 2, EUR 10.00
 -  Channel 3, EUR 10.00
 -  Channel 4, EUR 20.00
 -  Channel 5, EUR 20.00
 -  Channel 6, EUR 50.00
 -  Channel 7, EUR 50.00
 -  Channel 8, EUR 100.00
 -  Channel 9, EUR 100.00
 -  Channel 10, EUR 200.00
 -  Channel 11, EUR 200.00
 -  Channel 12, EUR 500.00

+0.001-0.001

+0.01-0.01

+0.1-0.1

+1-1

+10-10

+100-100

Currency

▼

CoinService

VDAI

LED-Effects...

Apply

Back

Meter impulse:

Counter 1	EUR 0.10
-----------	----------

Cashless Device

NONE

Cashless Device

In this menu you can activate/deactivate channels of your coin mech or banknote reader. Use the checkboxes next to the channels which you want to disable.

















For example: If you don't want 10 cent coins, deactivate channel A in the coin mech window.

- **Meter impulse**
After the chosen amount the counter of the meter will be increased by 1.
- **Currency**
Choose the programmed currency.

- **Coin Service**

With the button "CoinService" you can start a configuration tool for your coin mech. Here you can also test channels or program new coins (e.g. token).

CoinService V5.51 Copyright© by TAB-Austria

Select	Channel	Value	Currencyname	Manufacturer: CMG Product RM5HDC S/N: 571468 Address: 2 Modifiable: Yes Serial port Maxi USB
<input type="radio"/>	1		0.50 EUR 'A' European Union, Euro	<div style="border: 1px solid gray; padding: 2px; margin-bottom: 5px;">Change CoinSet</div> <div style="border: 1px solid gray; padding: 2px; margin-bottom: 5px;">Teach Channel</div> <div style="border: 1px solid gray; padding: 2px; margin-bottom: 5px;">Delete Channel</div> <div style="border: 1px solid gray; padding: 2px; margin-bottom: 5px;">Test Coinmech</div> <div style="border: 1px dashed gray; padding: 2px;">Exit</div>
<input type="radio"/>	2		1.00 EUR 'A' European Union, Euro	
<input type="radio"/>	3		2.00 EUR 'A' European Union, Euro	
<input type="radio"/>	4		xxxx xxxxx	
<input type="radio"/>	5		xxxx xxxxx	
<input type="radio"/>	6		xxxx xxxxx	
<input type="radio"/>	7		xxxx xxxxx	
<input type="radio"/>	8		xxxx xxxxx	
<input type="radio"/>	9		xxxx xxxxx	
<input type="radio"/>	10		xxxx xxxxx	
<input type="radio"/>	11		xxxx xxxxx	
<input type="radio"/>	12		xxxx xxxxx	
<input type="radio"/>	13		xxxx xxxxx	
<input type="radio"/>	14		xxxx xxxxx	
<input type="radio"/>	15		xxxx xxxxx	
<input type="radio"/>	16		xxxx xxxxx	

Sorry, cointable upload not possible (no coin table set found).

- **VDAI**

Settings for VDAI printer.

- **LED Effects...**

Settings for LED ring in table section.

- **Cashless Device**

Selection of type of cashless payment device

- None
- Payter
- Televend

Menu Bookkeeping

Date	Time																										
<table border="1"> <tr><td> 0.50</td><td>0</td></tr> <tr><td> 1.00</td><td>0</td></tr> <tr><td> 2.00</td><td>0</td></tr> </table>	0.50	0	1.00	0	2.00	0	<table border="1"> <tr><td colspan="2">Result</td></tr> <tr><td>Currency</td><td>EUR <input type="button" value="v"/></td></tr> <tr><td>Total In Cash</td><td>0.00</td></tr> <tr><td>Total In Card</td><td>0.00</td></tr> <tr><td colspan="2"><hr/></td></tr> <tr><td></td><td>0.00</td></tr> </table>	Result		Currency	EUR <input type="button" value="v"/>	Total In Cash	0.00	Total In Card	0.00	<hr/>			0.00								
0.50	0																										
1.00	0																										
2.00	0																										
Result																											
Currency	EUR <input type="button" value="v"/>																										
Total In Cash	0.00																										
Total In Card	0.00																										
<hr/>																											
	0.00																										
<table border="1"> <tr><td>Coins</td><td>0.00</td></tr> </table>	Coins	0.00																									
Coins	0.00																										
<table border="1"> <tr><td> 5.00</td><td>0</td></tr> <tr><td> 10.00</td><td>0</td></tr> <tr><td> 20.00</td><td>0</td></tr> <tr><td> 50.00</td><td>0</td></tr> <tr><td> 100.00</td><td>0</td></tr> <tr><td> 200.00</td><td>0</td></tr> <tr><td> 500.00</td><td>0</td></tr> </table>	5.00	0	10.00	0	20.00	0	50.00	0	100.00	0	200.00	0	500.00	0	<table border="1"> <tr><td>Test credits:</td><td>0</td></tr> <tr><td>Free game credits:</td><td>0</td></tr> <tr><td>Community Credits</td><td>8</td></tr> <tr><td>Tournament Credits</td><td>0</td></tr> <tr><td>Time running</td><td>165:21</td></tr> <tr><td>Time played</td><td>0:41</td></tr> </table>	Test credits:	0	Free game credits:	0	Community Credits	8	Tournament Credits	0	Time running	165:21	Time played	0:41
5.00	0																										
10.00	0																										
20.00	0																										
50.00	0																										
100.00	0																										
200.00	0																										
500.00	0																										
Test credits:	0																										
Free game credits:	0																										
Community Credits	8																										
Tournament Credits	0																										
Time running	165:21																										
Time played	0:41																										
<table border="1"> <tr><td>Bank notes</td><td>0.00</td></tr> </table>	Bank notes	0.00																									
Bank notes	0.00																										
<table border="1"> <tr><td> 1.00</td><td>0</td></tr> </table>	1.00	0																									
1.00	0																										
<table border="1"> <tr><td>Card Payments</td><td>0.00</td></tr> </table>	Card Payments	0.00																									
Card Payments	0.00																										
<table border="1"> <tr><td>Total In</td><td>0.00</td></tr> </table>	Total In	0.00																									
Total In	0.00																										
<input type="checkbox"/> Bookkeeping visible in the overview test menu																											
<table border="1"> <tr><td>QR-Code</td></tr> <tr><td>Bookkeeping 2</td></tr> <tr><td>Erase</td></tr> <tr><td>Back</td></tr> </table>		QR-Code	Bookkeeping 2	Erase	Back																						
QR-Code																											
Bookkeeping 2																											
Erase																											
Back																											

In the bookkeeping menu you can see every income of your machine and you have the possibility to delete the statistics. If you want to deactivate the bookkeeping menu for your supervisor, activate the checkbox at the bottom.

- **Bookkeeping 1**

Here you can see the complete income of coins and banknotes. You can also see test credits, free game credits, Community credits, the running time and the time played of your machine.

QR Code: Scan Bookkeeping to your smartphone.

- **Bookkeeping 2**

Here you can see an overview of the income, test-credits and the running time. This menu can be saved via pin code.

QR Code: Scan Bookkeeping to your smartphone.

Bookkeeping 2

Date Time

Result

Currency EUR v

Total In Cash 0.00

Total In Card 0.00

0.00

Test credits:	0
Free game credits:	0
Community Credits	0
Tournament Credits	0
Time running	93:52
Time played	0:41

QR-Code

Erase

Back

HINT:
Bookkeeping 1 and Bookkeeping 2 can be deleted separately.

Menu Game Price Settings

Game price setting

Money value	Credit	Currency
0.50	1	EUR

Introduce

Delete

+0,001 -0,001

+0,01 -0,01

+0,1 -0,1

+1 -1

+10 -10

+100 -100

Standard1 (normal) Standard2 (Bonus)

Free play mode

Apply

Back

- **Game price setting**
Here you can set the credit price.
To add more entries for bonus settings, click "Introduce".
You can change the amount of the entries by marking it and use the buttons on the right.
- **Free play mode**
To set the machine to free play mode, activate this checkbox.

Menu Games

	Game	Credit	Continue Credit
421	on	1	1
5th Gear California	on	1	1
Anubis	on	1	1
Around in Space	on	2	1
Around the World	on	2	1
Backgammon	on	1	2
Bet You Know It	on	1	1

Game setting

421

Game

on
 off

Game price

1
credit(s)

+1
-1
Default

Continue Price

1
credit(s)

+1
-1
Default

Statistic

Selected game All games

Apply

Back

In this menu you can enable/disable games, change continue/credit price of games or look at statistics.

Mark the game you want to configure and press the buttons to change the settings. To view statistics, press "Selected game" or "All games".

Menu PIN Settings

Select the PIN number to be changed and then enter the new PIN number!

set PIN for

Supervisor 1	****	change
<input type="checkbox"/> Activate		
Supervisor 2	****	change
<input type="checkbox"/> Activate		
Supervisor 3	****	change
<input type="checkbox"/> Activate		

set PIN for

Testmode	****	change
<input type="checkbox"/> Activate		

set PIN for

Bookkeeping 2	****	change
<input type="checkbox"/> Activate		

Back

In the menu Pin settings, you can set up three different pin codes. Press the button "change" of the pin you want to configure and insert it two times in a row, afterwards activate the checkbox "Activate".

- **Supervisor 1**
Enables a small testmode for your supervisor (for details see below).
- **Testmode**
Pin request before the testmode starts.
- **Bookkeeping 2**
Pin request to access Bookkeeping 2 menu.

Supervisor Testmode

If you activated a supervisor 1 pin code, your supervisor could access a small testmode by pressing the Fun4Four logo in the main menu and clicking "Supervisor".

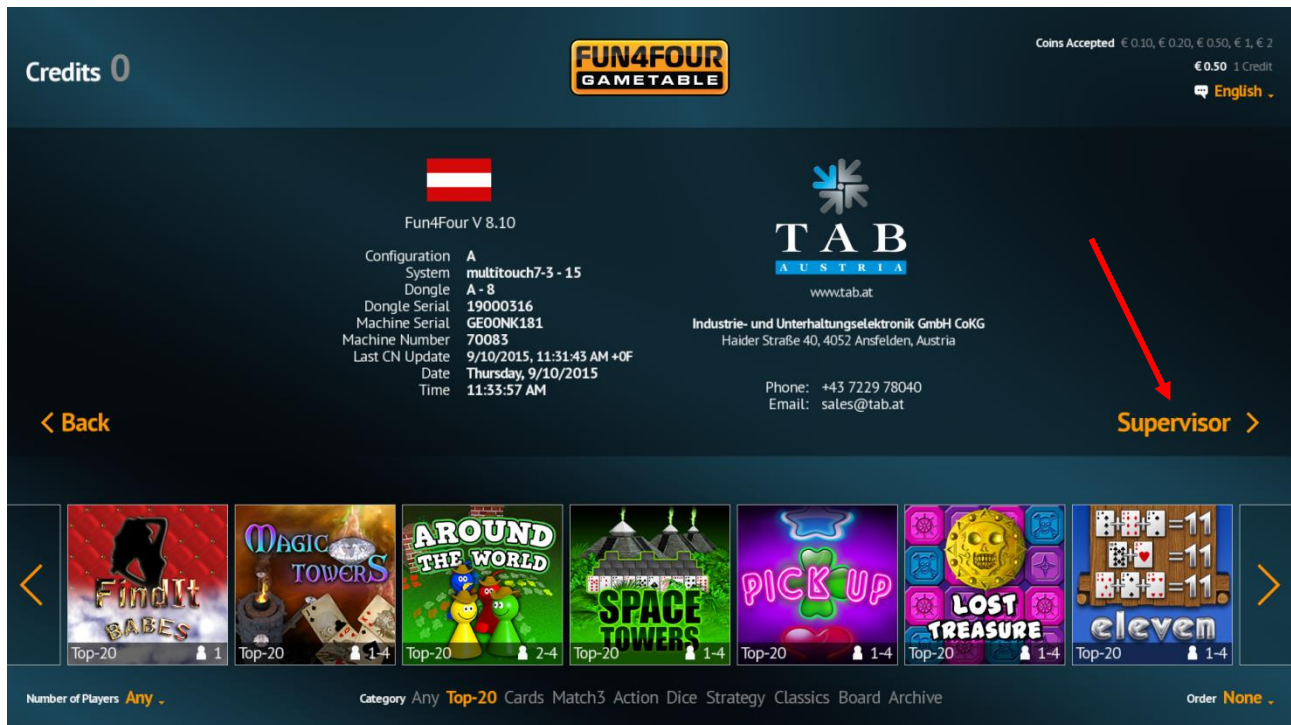

In the **Supervisor testmode** only a few settings can be changed

- Volume settings
- LED effects
- etc.

Menu ChampionsNet

In the menu ChampionsNet you can set up the internet settings and register the Fun4Four by TAB – Austria.

Machine/Set-up site

Machine number	69932
Name of the establishment	
Place/Town	
Address	
Telephone number	
Fax number	
Email	
Country	Austria

Connection (Network - Direct)

Telephone number

User name

Time 13:10

Activate

To enable high scores on your machine, press the checkbox **“Activate”**.

To set up your internet connection, please press **“change”** at Connection.

Provider connection

Telephone number	<input type="text"/>	<input type="button" value="change"/>
User name	<input type="text"/>	<input type="button" value="change"/>
Password	<input type="text"/>	<input type="button" value="change"/>
Confirmation	<input type="text"/>	<input type="button" value="change"/>

Start of transmission

Hour Minute

<input type="text" value="18"/>	<input type="text" value="10"/>	<input type="button" value="+"/> <input type="button" value="-"/>
---------------------------------	---------------------------------	--

Connection

Network - VPN

Network - Direct

Network - PPPOE

Permanent Connection

- **Start of transmission**
 With the plus/minus buttons you can change the time for the automatic data transmission of the Fun4Four with the TAB-server. Please note that normally the Fun4Four should be switched on at that time.
- **Connection**
 Choose your connection type here, normally the standard configuration „**Network Direct**“ should be the right one for you network.

HINWEIS:
 To start the configuration of your WLAN adapter, press “Netgear WLAN”.

- Page 2...

Press „Page 2...” to access more settings for your network.

Proxy/Auto Configuration Script

Enable Proxy

Enable Config Script

DNS

Domain:

DNS1:

DNS2:

Network Info

Use DHCP

IP Address:

Subnet Mask:

Gateway:

The standard configuration “Use DHCP” should be correct in most cases, if there are specific settings needed, deactivate the checkbox and fill in the right settings from your network administrator.

Menu Online Terminal Management (OTM)

Machines with Online Terminal Management activated, have many advantages towards offline machine:

- **New games**
You get automatically new games without any effort.
- **Community games**
Exclusive games for you Fun4Four with OTM from external partners of TAB-Austria.
- **Online updates**
The latest Fun4Four version will be automatically installed on your machine. New functions will be instantly available for you and your customers.
- **Online accounting**
You can make a settlement or create statistics of the income of your machine.
- **Advertisement**
Upload without any effort advertisement pages to your Fun4Four.
- **And much more ...**

Before you can register your Fun4Four in the Online Terminal Management, you have to set up an OTM-account from the company TAB-Austria on the webpage <https://otm.tab.at>.

After the successful registration login in your account and choose the option "Tan Codes" in the tab "Administration". There you will get a TAN code, which you need during the registration of the machine. The Tan code will be needed to match the machine to your account.

Afterwards start the testmode and click "**ChampionsNet**". Fill in all information which is needed in the marked fields and click "**Register**" and "**New registration**".

The machine will be registered at the TAB-server and will get a unique machine number.

After the registration the button "Online Service (OTM)" is activated, click it to enable OTM on your machine.

Machine/Set-up site

Machine number	70083
Name of the establishment	Fun4Four
Place/Town	4052
Address	
Telephone number	
Fax number	
Email	
Country	Austria

Connection (Network - Direct)

Telephone number
User name
Time 09:00



Activate

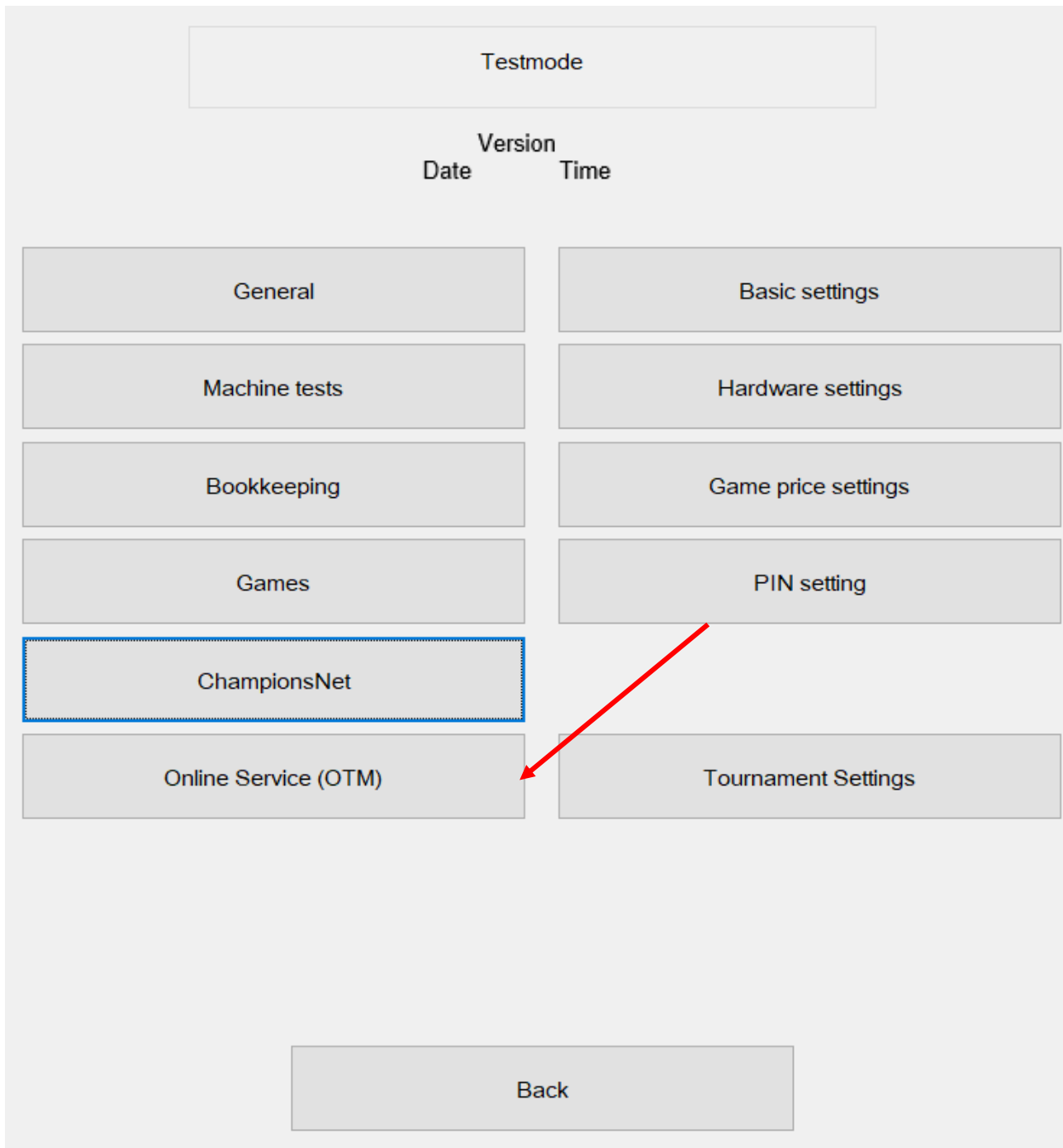

Follow the steps on the display.

After the fill in of the TAN code from your OTM account, the machine number and the actual meter count the machine is fully configured and can be used.

Program update

If your machine is registered in the Online Terminal Management, you will always have the latest version on your machine, because it will be updated automatically. If you want to do a manual update, you can do this with a USB stick.

Login in your OTM account at <https://otm.tab.at> and click “**Download**”. Download the description for creating an update stick / disk here and follow the step-by-step instruction.

If you already have an update stick or ordered one from TAB-Austria, you can start with the following procedure.

Procedure

- Switch machine off
- Dock the USB stick to a USB port
- Switch machine on
- Copy procedure is starting automatically; this is taking about 4-8 minutes.
- Turn machine off at final message “Update finished ”
- Remove the update disk
- Turn on the machine again
- Machine starts now with new software

Troubleshooting

Failure	Solution
Touch screen inaccurate	<ul style="list-style-type: none"> - Check grounding
Touch screen does not work	<ul style="list-style-type: none"> - Check the USB connection from the touch controller to the PC - Check the power connection from the touch controller - Do new calibration (Testmode – General) - During the update, the touch screen must be connected to a USB 2.0 port
Display shows „No Signal “	<ul style="list-style-type: none"> - Check monitor cable from display to PC - Check if the PC starts (CPU fan is running), if it does not, the problem must be in the PC
Display is black	<ul style="list-style-type: none"> - Check power connection from the display - If PC does not start, check the power connection from the whole machine (inclusive line filter)
PC does not start	<ul style="list-style-type: none"> - Check power connection on power supply - Check power connection and fuses in the line filter
Machine does not start and peeps	<ul style="list-style-type: none"> - Plug RAM memory in and out
Fun4Four has no sound	<ul style="list-style-type: none"> - Check green sound cable at PC

Failure	Solution
Coin mech does not recognize coins	<ul style="list-style-type: none"> - Clean coin mech - Check connector from coin mech if it's correctly plugged in - Check if currency is correct in test mode – hardware settings and if channels are shown, if not, coin mech must be replaced
Banknote reader does not recognize banknotes	<ul style="list-style-type: none"> - Clean banknote reader - Check connector from banknote reader if it's correctly plugged in - Check if currency is correct in test mode – hardware settings and if channels are shown, if not, banknote reader must be replaced - If LED on banknote reader red or does not light, it must be replaced
Coin mech and banknote reader do not work	<ul style="list-style-type: none"> - Check I/O controller plug (50 pin) on PC
Software does not start	<ul style="list-style-type: none"> - Call Hotline with the error message +43 7229 78040 – 250 - Try to upload the software again - Change hard disk

Maintenance Operating Elements

Coin Acceptor

Comestero RM5HD

Acceptor maintenance

This fact sheet provides the necessary information for the clearing and maintenance of the RM5HD electronic coin validator.

Cleaning at regular intervals assures a high-quality standard of coin recognition and, in the long run, reduces the risk of error and failure.

External cleaning

The external surfaces of the coin validator are made of a plastic shockproof material (ABS). To clean them it is recommended to use a soft cloth with a neutral detergent. For more resistant dirt ethyl alcohol can be used. To remove excess dust from the coin slots and other narrow spaces the use of compressed air or a paintbrush is recommended.

ATTENTION:

Do not use sharp or abrasive tools, which could damage the surface and the recognizing sensors.

Do not put the coin validator in water or any other type of liquid.

Internal cleaning

In the RM5HD electronic coin validator the coin recognizing sensors are installed behind a small spring door. Open the door to have access to this space as shown (fig.1).

Clean the excess dirt from behind the door with a grease removing spray, for example a normal detergent for windows and mirrors, removing more resistant dirt with a small brush.

Ethyl alcohol can be used. Do not touch or spray the sensors!

There are three small holes behind the door. These holes are where the coin recognizing sensors are put in place (fig.2). If dust or dirt blocks these holes the performance of the coin validator could be reduced and, in extreme cases, no coins would be recognized.

To keep the sensors clean, whilst in position use compressed air only.



Fig.1



Fig.2

ATTENTION:

Do not use any type of sharp object, such as pins or screw drivers, to remove dust from the sensors as they could be irreparably damaged putting the coin validator out of use.

If the coin validator is still inefficient after cleaning do not hesitate to contact our hotline.

NRI G-13 mft

Acceptor maintenance

The coin validator must only be wiped clean from time to time with a damp cloth (lukewarm water with some detergent). Beyond that, no further maintenance work is required.

Under no circumstances may the cloth be so wet that fluid runs into the device. Otherwise, the PCB will be damaged.

Do not use any solvents or scouring agents that will attack the plastic material of the device.

1. Pull the machine's mains plug
2. Carefully open the flight deck on the left-hand side and hold it open
3. Use a cloth to wipe off the coin runway inside the coin validator.
4. Close the flight deck again.
5. Reconnect the machine to the mains supply.

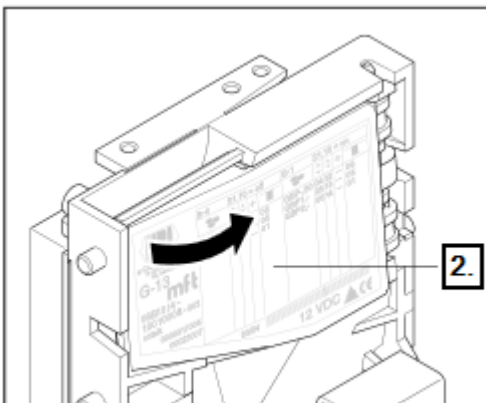

Open the flight deck of the coin validator.

Bill Acceptor

Astro GBA ST2

Periodical Cleaning

Depending on the environment and amount of use, the ST2 currency validator may require routine

- Maintenance to restore optimum performance
- Under normal use, the currency validator should be checked every **2 to 4 months**
- For unusual operating conditions, such as when the currency validator is exposed to a smoky environment, dirt, dust, water spray, airborne oil, and/or sand, more frequent maintenance is required.

Cleaning Process

1. Power down the currency validator and disconnect the external host loom.



2. To remove the GBA ST2 from the faceplate, gently push the two purple bezel retainer buttons inwards until they are in contact with the validator.
With these depressed, pull on the validator to remove from its locking stage.



3. Move the two purple latches inwards to unlatch and then gently pivot top section backwards to open and remove.

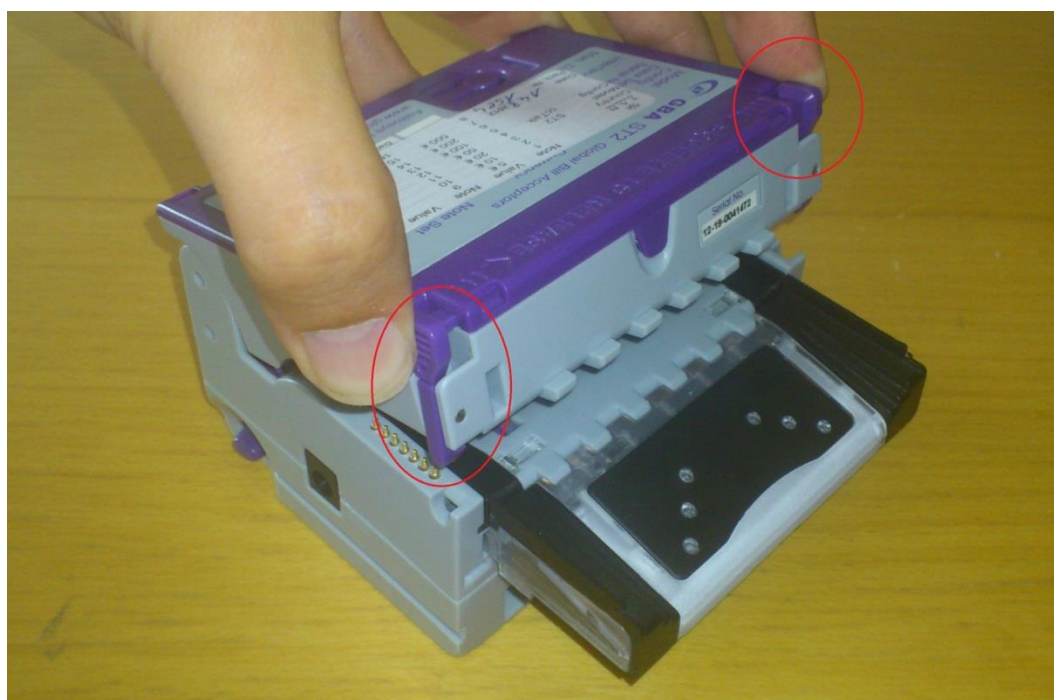

4. Please use a cotton swab or lint-free cloth and a cleaning solution -- a mix of water and up to 50 % Iso Propyl Alcohol (IPA) is recommended.

- DO NOT use more than 50 % IPA. NEVER use solvent--based cleaning agents, such as pure alcohol, petrol, methylated spirit or white spirit on this product as the unit will be severely damaged.
- Using the Cotton swab or cloth dipped in the cleaning solution - carefully clean all sensors and plastic windows using light force only.



- Continue with swab to clean note path, all rollers and belts.
 - Use an additional swab or cloth to dry area cleaned, if required.
 - Reconnect host loom.
5. To refit the currency validator to the faceplate simply, insert the two black locating legs into the holes and push fully until you hear a loud clipping sound.
 6. Pull fully on the validator to ensure correct fitment.

Calibration

Although calibration of the Astro ST2 is not necessary, it is recommended periodically for preventative maintenance, and after any change to the software configuration of the unit. To carry out this calibration you need two adjustment papers for the Astro ST2. (Order number: 28600035 - Calibration paper set Astro ST2).



Procedure:

1. Push button 3 times, the rear diagnostic LED will rapidly flash orange to show the unit is in calibration mode.



2. Insert the white calibration paper. It should be presented in the center of the note path and square to the direction of travel. The currency validator will draw-in the paper all the way into the cassette; hold it momentarily before returning it in several short steps.
3. Remove the white calibration paper and insert the black calibration paper. The unit will draw-in the paper and return it immediately in one smooth action.
4. Calibration is complete.

If calibration has not been successful, the diagnostic LED will repeatedly flash a four-color error code until the push button is pressed to cancel.

Block Diagram Power Cables

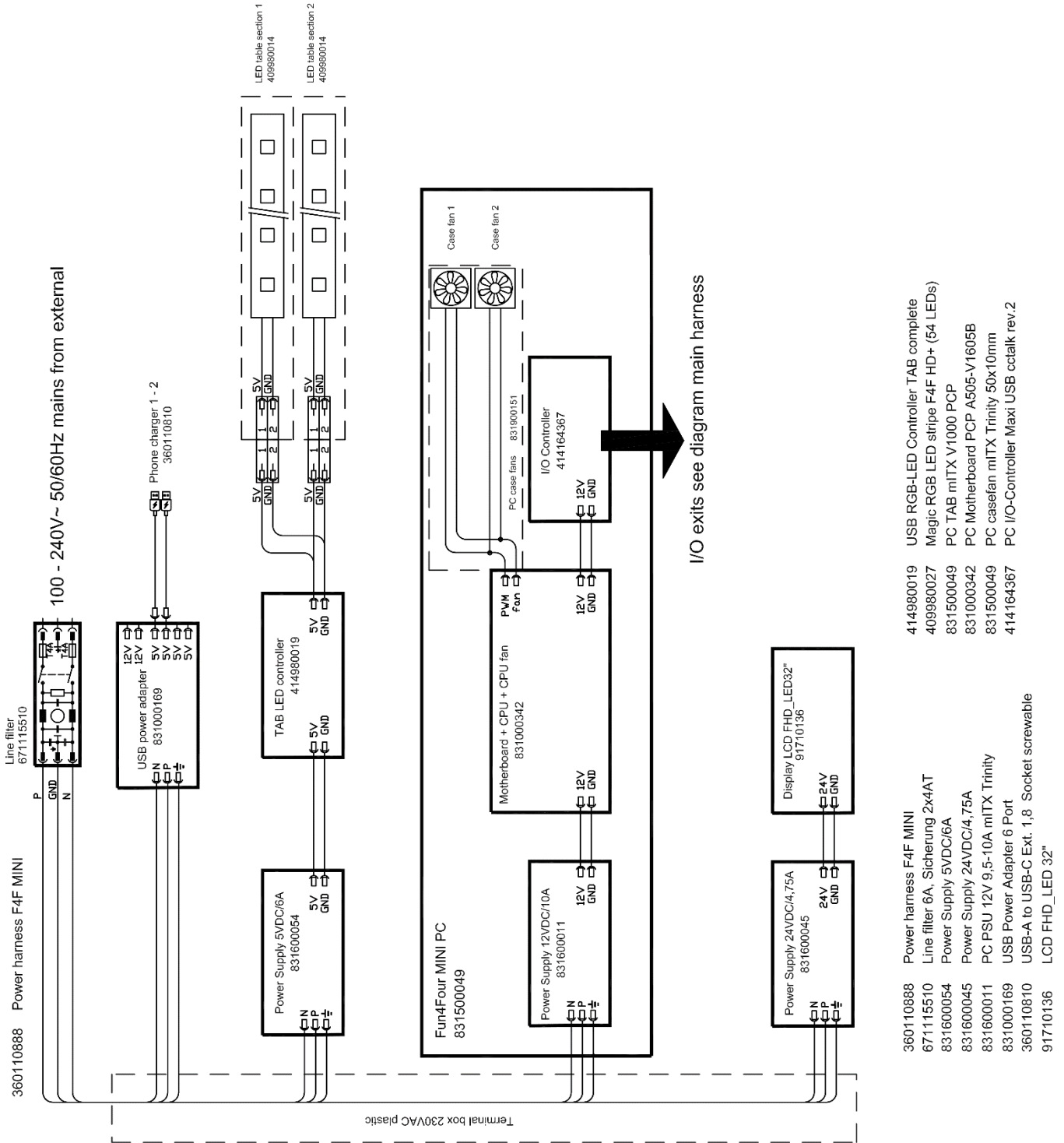

Exploded Assembly Drawings

Exploded Drawing Fun4Four Evo

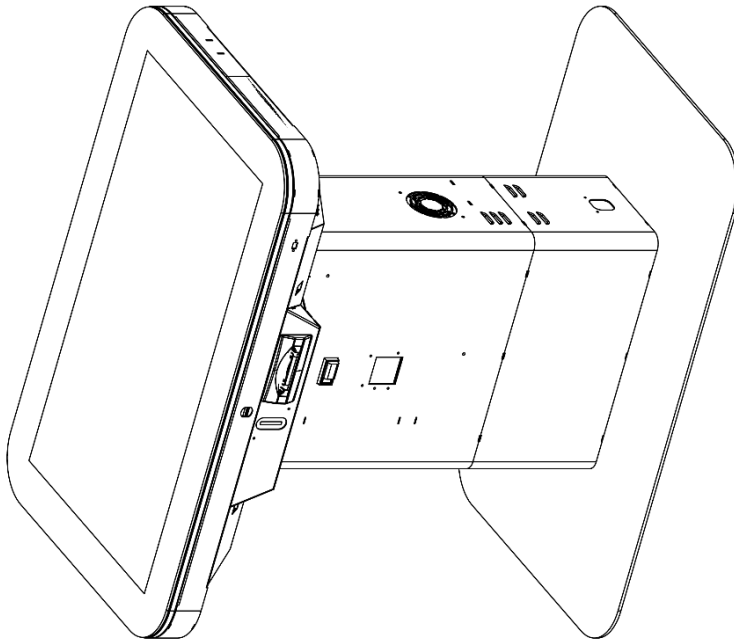

Mögliche Farben: RAL9005 Tiefschwarz
 Available colours: RAL9005 deep black

RAL9010 Reinweiss
 RAL9010 pure white

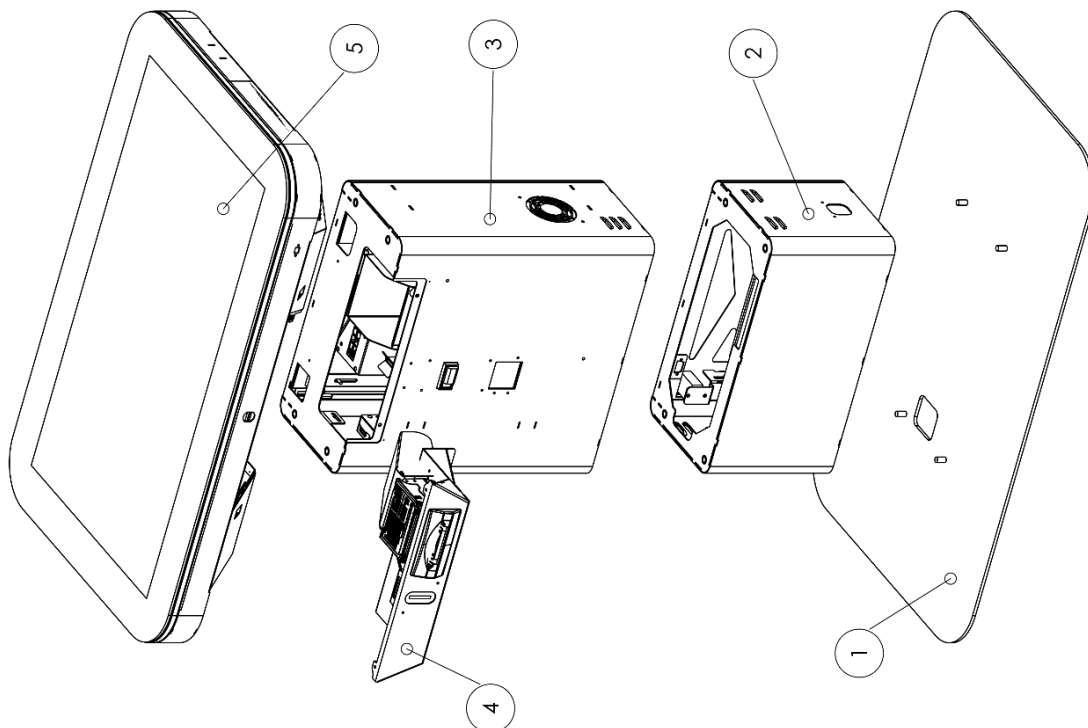

Pos	Benennung	Name	ArtNr	Menge
1	Bodenplatte F4F mini	Baseplate F4F mini	022130506-colour	1
2	Baugruppe Kassensegment F4F mini	Assembly Cash box section F4F mini	7397	1
3	Baugruppe PC Segment F4F mini	Assembly PC section F4F mini	7397	1
4	Baugruppe Einzeleinheit F4F mini	Assembly Deposit section F4F mini	7397	1
5	Baugruppe Tischsegment F4F mini	Assembly Table section F4F mini	7397	1

Assembly Cash Section

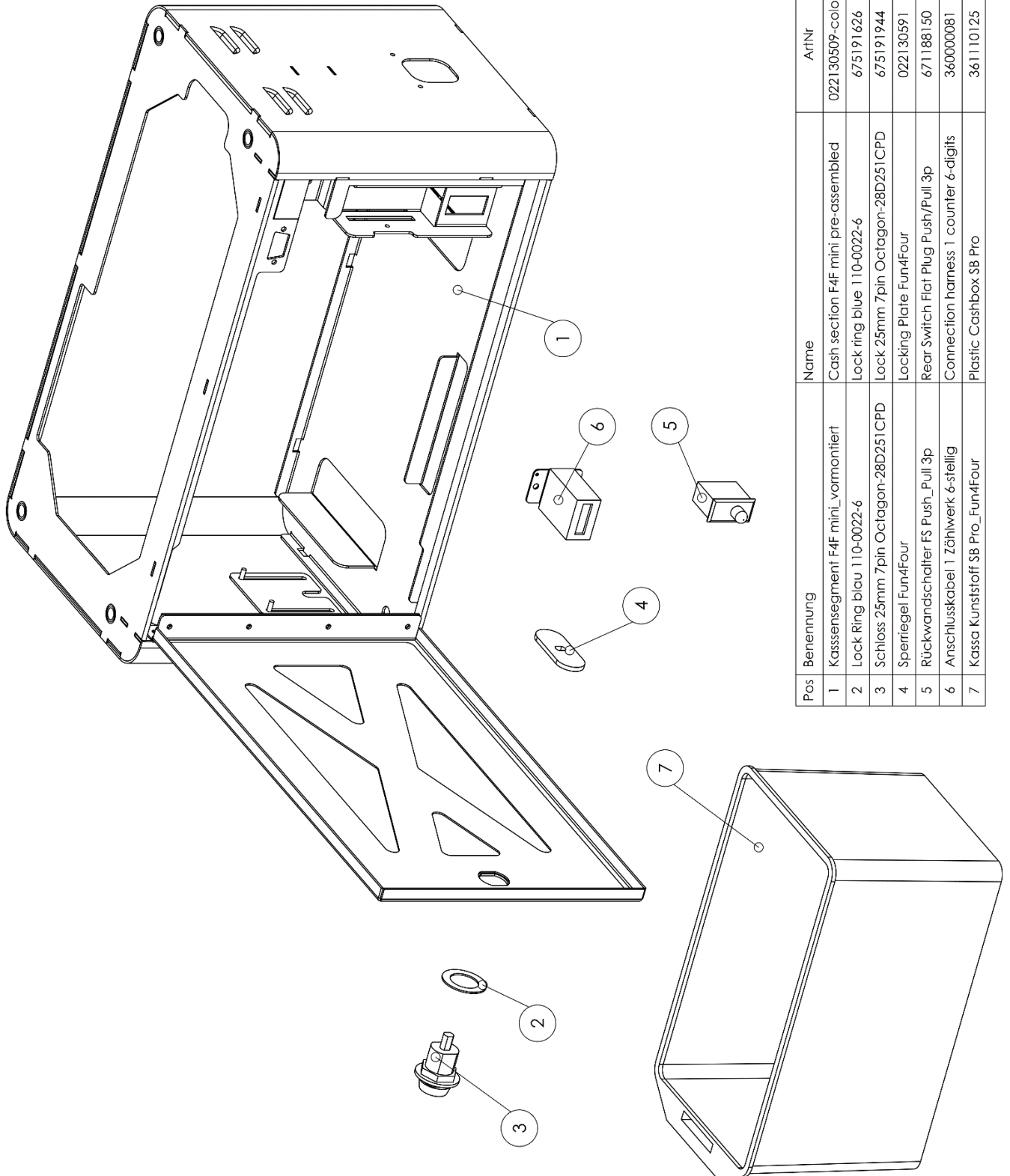

Pos	Benennung	Name	ArtNr	Menge
1	Kassensegment F4F mini_vormontiert	Cash section F4F mini pre-assembled	022130509-colour	1
2	Lock Ring blau 110-0022-6	Lock ring blue 110-0022-6	675191626	1
3	Schloss 25mm 7pin Octagon-28D251CPD	Lock 25mm 7pin Octagon-28D251CPD	675191944	1
4	Sperriegel Fun4Four	Locking Plate Fun4Four	022130591	1
5	Rückwandschalter FS Push_Pull 3p	Rear Switch Flat Plug Push/Pull 3p	671188150	1
6	Anschlusskabel 1 Zählwerk 6-stellig	Connection harness 1 counter 6-digits	360000081	1
7	Kassa Kunststoff SB Pro_Fun4Four	Plastic Cashbox SB Pro	361110125	1

Assembly PC Section

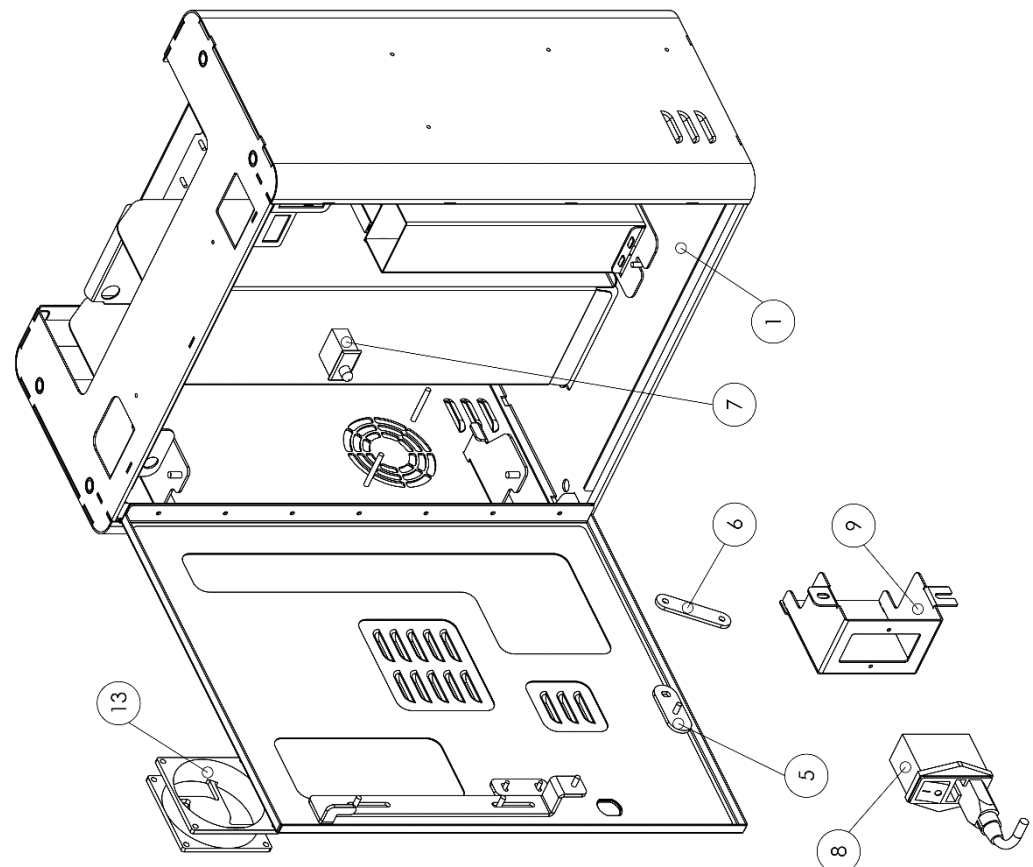
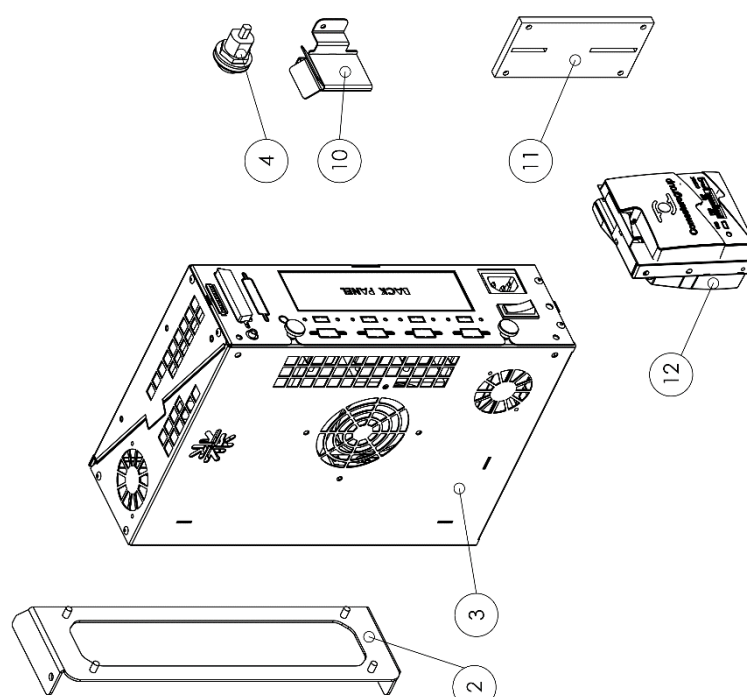

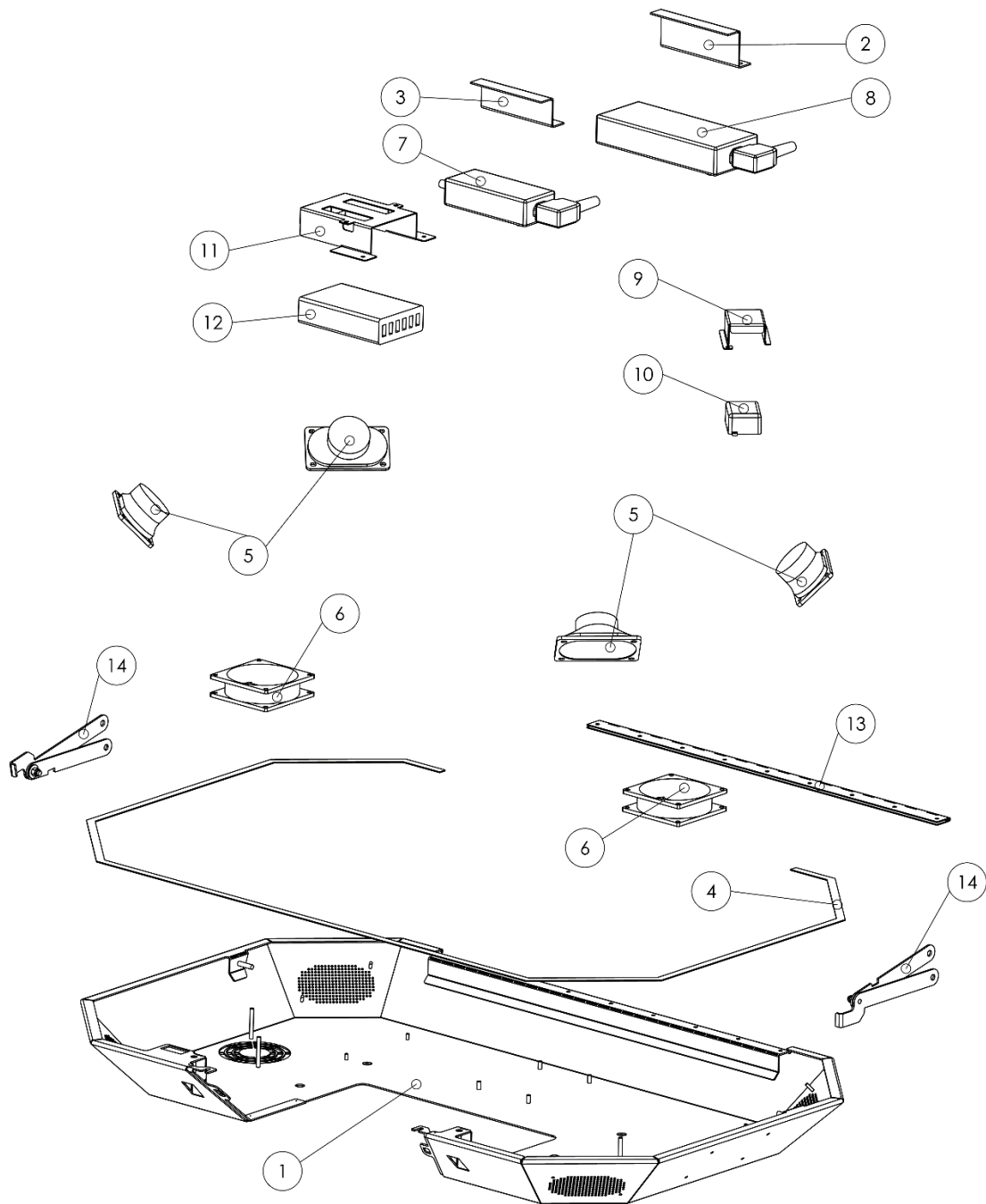

Pos.	Benennung	Name	ArtNr.	Menge
1	PC Segment F4F mini_vormontiert	PC section F4F mini_pre-assembled	022130562-colour	1
2	Drehwinkel PC F4F mini	Rotation angle PC F4F mini	022130566	1
3	PC TAB mitX V1000 PCP	PC TAB mitX V1000 PCP	831500049	1
4	Schloss 25mm 7pin Octagon-28D251CPD gelb	Lock 25mm 7pin Octagon-28D251CPD yellow	675191944	1
5	Spiegel PC Segment Fun4Four	Locking plate PC Fun4Four	022130598	1
6	Gelenk Spenstange PC Tür Fun4Four	Hinge locking bar PC door Fun4Four	022130593	1
7	Rückwandschalter FS Push_Pull 3p	Rear Switch Flat Plug Push/Pull 3p	671188150	1
8	Kombinetzfilter 6A_Sicherung 2x4AT	Linefilter 6A_Fuse 2x4AT	671115510	1
9	Netzfilterhalterblech F4F mini	Mourning plate line filter F4F mini	022130564	1
10	BG Münzrichter 4mm Fun4Four	Coin funnel 4mm Fun4Four	361138323	1
11	Münzprüferblende Mini für Seci RM-FI	Front Plate Mini for Seci RM-FI	464065245	1
12	Münzprüfer RM5HD ccTalk B - GEH306 SN	Coin Acceptor RM5HD ccTalk B - GEH306	464138719	1
13	Lüfter 80x80mm 1900RPM mit .JST Stecker	Fan 80x80mm 1900RPM with .JST Connector	416900056	1

Assembly Table Section F4F Evo

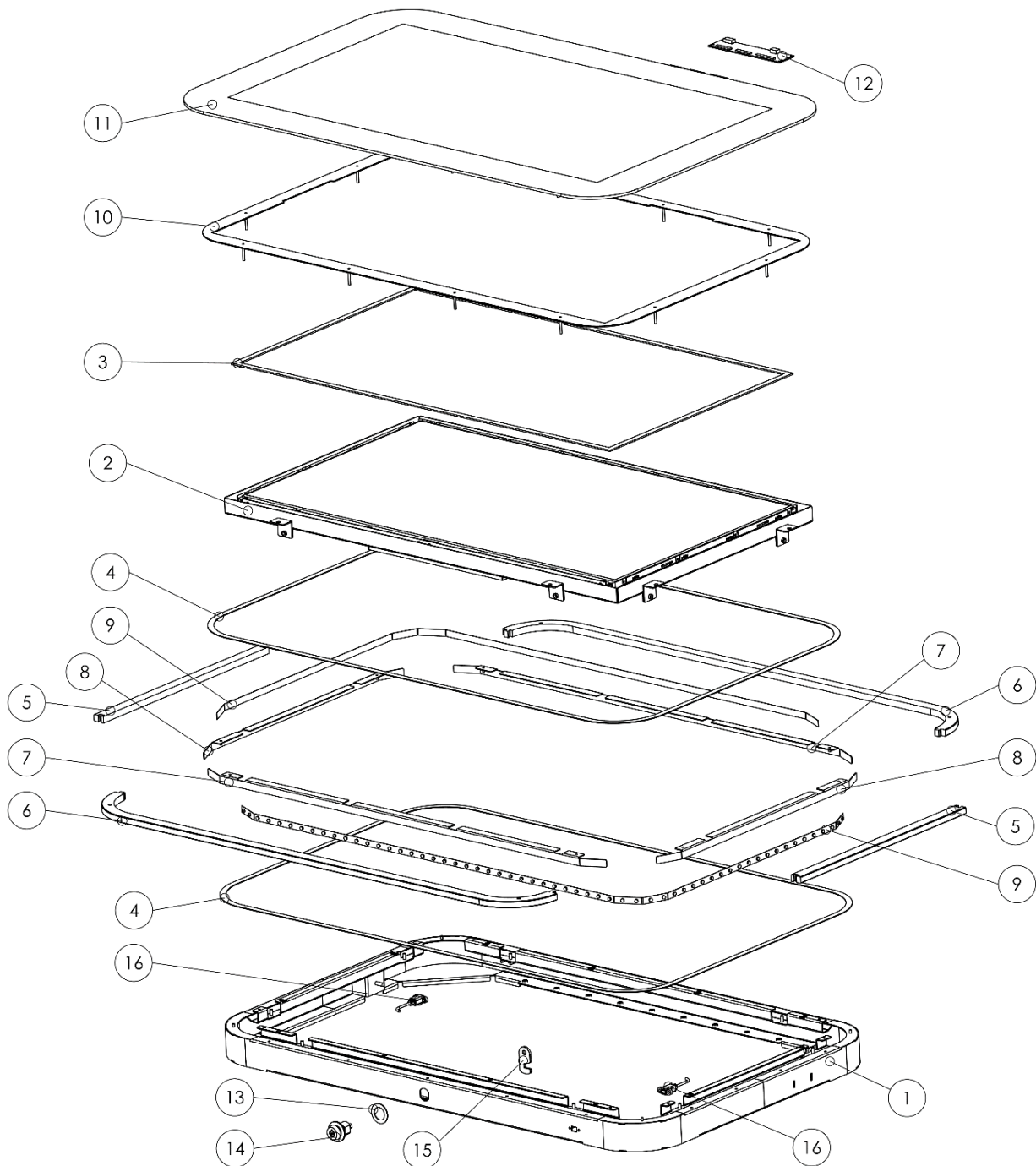

Pos	File Name	Name	ArtNr	Menge
1	BG Korpus Tischsegment F4F mini	Table section F4F mini	022130563-colour	1
2	Halteblech Netzteil Display Casino	Bracket power supply display Casino	022130766	1
3	Halteblech Netzteil f. Wettautomat	Bracket power supply betting terminal	022082016	1
4	Dichtung Schaumband 9x2mm 10.2026.3209	Foam sealing 9x2mm 10.2026.3209	364191320	1
5	Lautsprecher XF-203-494, 4 Ohm	Loudspeaker XF-203-494, 4 Ohm	412120264	4
6	Lüfter 80x80mm 1900RPM mit JST Stecker	Fan 80x80mm 1900RPM with JST connector	416900056	2
7	Steckernetzteil 5VDC 4,5A	Power Supply 5VDC 4,5A	831600053	1
8	Steckernetzteil 24VDC 5A	Power Supply 24VDC/5A	831600045	1
9	Montageblech LED Controller MF HD+	Mounting plate LED Controller MF HD+	022131335	1
10	USB RGB-LED Controller TAB komplett	USB remote RGB-LED controller TAB	462980019	1
11	Montagewinkel USB Charger Fun4Four	Bracket USB charger Fun4Four	022131353	1
12	USB Power Adapter 6 port	USB Power Adapter 6 Port	831000169	1
13	Scharnier Displayeinheit F4F mini	Hinge displayframe F4F mini	022130537	1
14	BG Haltebügel Displayfront F4F mini	Holding bar for displayfront F4F mini	022130976	2



Pos	File Name	Name	ArtNr	Menge
1	BG Grundrahmen Display F4F mini	Main frame display front F4F mini	022131414-colour	1
2	LCD FHD_LED 32"	LCD FHD_LED 32"	91710136	1
3	Dichtung Schaumband 9x2mm 10.2026.3209	Foam Sealing 9x2mm 10.2026.3209	364191320	1
4	Dichtung Schaumband 9x2mm 10.2026.3209	Foam sealing 9x2mm 10.2026.3209	364191320	2
5	Lichtleiste oben_unten F4F mini	Lightbar top_bottom F4F mni	672166035	2
6	Lichtleiste seitlich F4F mini	Lightbar side F4F mini	672166034	2
7	Montageleiste LED Stripe seitlich F4F mini	Bracket LED stripe side F4F mini	022130539	2
8	Montageleiste LED Stripe oben_unten F4F mini	Bracket LED Stripe top_bottom F4F mini	022130538	2
9	Magic RGB LED stripe MF HD+ (59 LEDs)	Magic RGB LED stripe MF HD+ (59 LEDs)	409980014	2
10	Trägerplatte Touch Screen F4F mini	Mounting plate touch screen F4F mini	022130536	1
11	Touch screen 32" PCAP F4F mini	Touch screen 32" PCAP F4F mini	462930212-colour	1
12	32inch Multitouch Controller EXC86H68108STBG	Touch controller EXC86H68108STBG	462930211	1
13	Lock Ring schwarz	Lock ring black	675191629	1
14	Schloss 25mm 7pin Octagon-28D251CPD	Lock 25mm 7pin Octagon-28D251CPD	675191944	1
15	Sperrbügel Displayeinheit F4F mini	Lock bar display section F4F mini	022130568	1
16	Verlängerung USB-A auf USB-C Buchse 1,8m schraubbar	Extension USB-A auf USB-C socket 1,8m screwable	360110810	2

Assembly Deposit Section Drawing

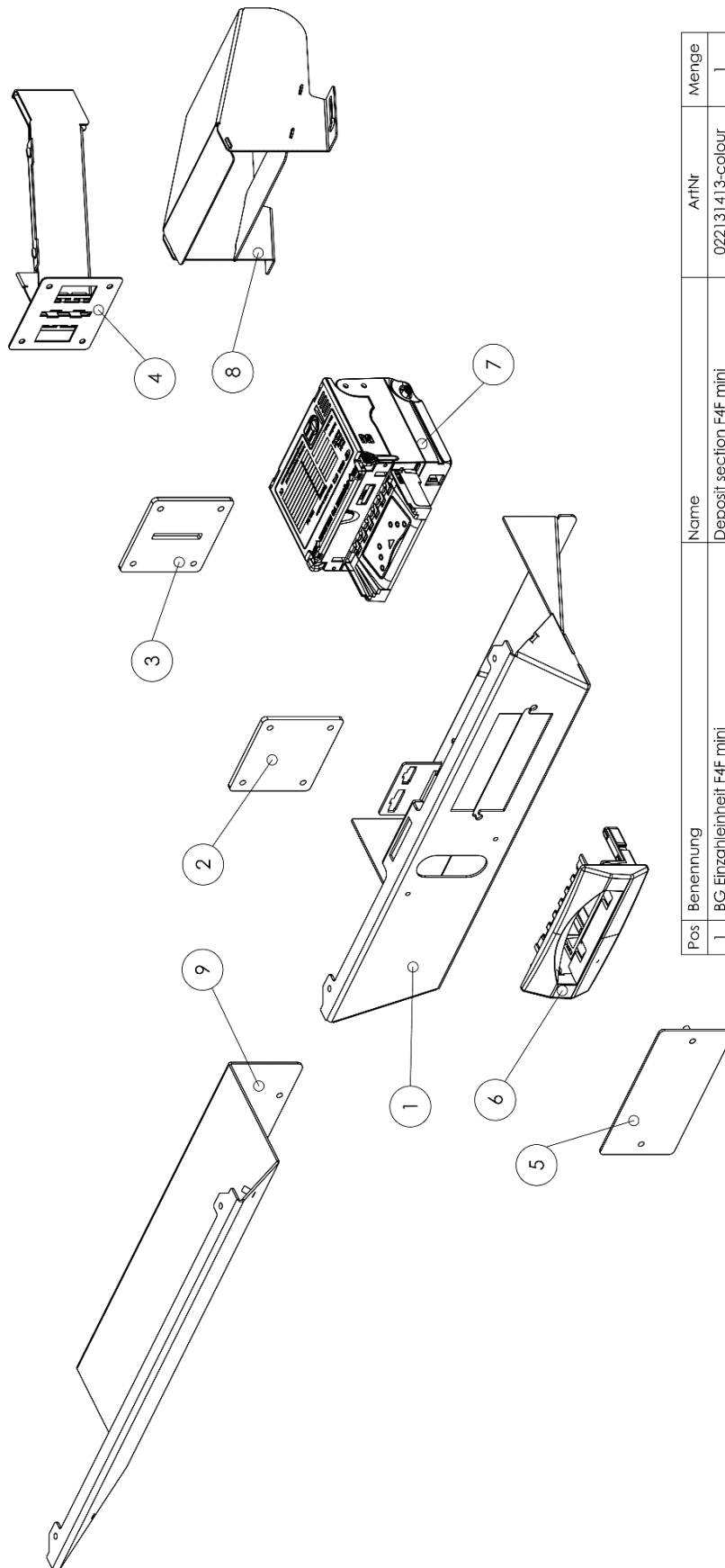

Pos	Benennung	Name	ArtNr	Menge
1	BG Einzleinheit F4F mini	Deposit section F4F mini	022131413-colour	1
2	Plexiabdeckung Münzeinwurf F4F_BL5012	Plexicover Coinslot F4F_BL5012	672220457-BL5012	1
3	Plexi Münzeinwurf Fun4Four	Plexi coinslot 3.5x35 Fun4Four	673220456	1
4	BG Münzkanal F4F mini	Coin channel F4F mini	022130565	1
5	Blindabdeckung Akzeptor ST2 Fun4Four	Cover note reader ST2 Fun4Four	022080303-colour	1
6	Blende Standard (Smiley) Astro ST2	Bezel Standard (Smiley) Astro ST2	022130526	1
7	Banknotenpr Astro GBA ST2-S25	Bill Acceptor Astro GBA ST2-S25	010100582	1
8	BG Notenkanal ST2 F4F mini	Note channel ST2 F4F mini	022130567	1
9	Abdeckung Serviceschacht F4F mini	Cover serviceslot F4F mini	022131531-colour	1

EC Declaration of Conformity



EU Declaration of Conformity

Document number: QZ 1000/113/01/08072021

Manufacturer: TAB-AUSTRIA Holding GmbH
Haider Straße 40
4052 Ansfelden

+43 (0)7229/78040

Amusement machine

Model: FUN4FOUR Evo

The product is in compliance with the requirements of the following European directives:

2014/30/EU	Electromagnetic Compatibility (EMC)
2014/35/EU	Low Voltage Directive (LVD)
2011/65/EU 2015/863	Restriction of the use of certain hazardous substances in electrical and electronic equipment (RoHS)

The compliance with the requirements of the European Directives was proved by the application of the following harmonised standards:

EMC:	EN 303 446-1 V1.2.1 Report T251-0236/21
LVD:	EN 62368-1:2014 + A11 2017 BS EN 62368-1:2014 + A11 2017 Report T223-0401/21
RoHS:	EN 63000:2018

Year of CE marking 2021

Place, date: Ansfelden, July 08th, 2021

Issued by: TAB Austria

Managing Director: MBA Thomas Stoyer



TAB Austria Industrie und
Unterhaltungselektronik GmbH & Co KG
Haider Straße 40
4052 Ansfelden
Austria
Tel: +43 7229 78040-0

Legally binding signature and company stamp

The declaration certifies the compliance with the mentioned criterions, but it doesn't include the assurance of characteristics.
The safety regulations in the product documentation must be observed!

Special Business Terms OTM

1. Standard Business Terms

The "Standard Business Terms of TAB-AUSTRIA Industrie- und Unterhaltungselektronik GmbH & Co KG" shall apply unless modified or supplemented by these Terms. You will find the "Standard Business Terms" at www.tab.at. TAB shall not assume any liability for the accessibility of OTM servers, for which reason no claims may be derived from their temporary inaccessibility.

Any eventual damage compensation claims shall be governed by the provisions of the "Standard Business Terms of TAB-AUSTRIA Industrie- und Unterhaltungselektronik GmbH & Co KG".

Compensation for any eventual indirect defect damages shall be limited to direct damages up to one-half of the licence fees for OTMs billed within the previous 12 months and the client shall only be entitled to them if we or our vicarious agents have been guilty of extremely gross negligence or deliberate intent. There shall only be damage compensation claims in case of deliberate intent or extremely gross negligence and they shall be limited in their amount. TAB shall not assume any liability in regard to errors and erroneous data caused by circumstances under the client's control (such as a defective client terminal).

This contract may be cancelled by either party as of the end of each month if advance notice of one week has been complied with.

In case of contract breaches, in particular untimely payment of licence fees for OTMs, for music titles or other services based thereon, TAB shall be entitled to block services, fully or partially, or to cancel the contract with immediate effect.

Should one or more of the provisions below be or become void or unenforceable then the validity of the remaining provisions shall not be impaired thereby. The void or unenforceable provision shall instead be replaced by a valid or enforceable one accomplishing as much as possible the commercial purpose pursued with the initial one.

2. Billing by email

Invoices for OTM services shall be sent to you by email at the email address given by you in connection with OTM registration. You hereby waive postal conveyance of the invoice. On the receiving end you must ensure that all electronic transmissions of the invoice by email can be properly delivered to you and that technical facilities such as filter programmes or firewalls are adjusted accordingly. Any eventual automatic electronic responses (e.g. notice of absence) cannot be taken into account by TAB and shall not be deemed to prevent valid receipt. TAB shall not be liable for damages resulting from any eventually enhanced risk to an electronic transmission of the invoice by email compared with conveyance by post. The client shall bear the enhanced risk of access by unauthorised third parties due to storage of the electronic invoice.

3. Music downloads

With delivery of music items you do not acquire the right to reproduce the music. You must acquire the rights to reproduction of music (downloading the music to another hard drive, backing up of music (not acquired from TAB) on the hard drive (regardless of where it originated), reproduction of the musical hard drive content, etc.), from austro mechana and LSG. We therefore request that you in such cases contact austro mechana, Baumannstrasse 10, 1031 Vienna (tel: +43/(0)1/71787) and LSG, Schreyvogelgasse 2/5, 1010 Vienna (tel: +43/(0)1/53560350), the authorised provincial agency or the commercialisation companies authorised in your country.

The music may only be opened on a terminal manufactured by TAB. The same shall apply for any eventual music updates you may acquire from TAB. You merely acquire the right to open this music on a single terminal. The rights to open it on additional terminals must likewise be acquired from the companies identified above (or from TAB).

The music you have acquired serves solely for public performance and may neither be passed on nor sold by you to third parties. The rights to public performance of music (playing of music in restaurants, gaming casinos, etc.) must be acquired from the authorised commercialisation company (in Austria: AKM) in return for a licence fee.

TAB is entitled during all of the client's usual business hours to check on the legality of the music opened on one of its manufactured terminals.

4. Online service

TAB shall not assume any liability for the accuracy or completeness of stored data. It must be explicitly pointed out that storage of the data on the online service does not release the client from keeping statutorily mandated records and does not replace the latter. Service and statistical data are in any case saved for six months. Tournament data are saved for at least six months after the end of the tournament. TAB reserves the right to delete older data. The client explicitly agrees that the personal data of the client and the players are not deleted unless this is expressly demanded; the client will inform the players of this in a corresponding form.

5. Advertising measures

TAB endeavours to increase your sales by means of advertising and motivational measures. You hereby consent to allowing TAB, to an appropriate extent, to produce credit vouchers for the free use of your TAB products and to distribute them to final customers. You will not prevent final customers from redeeming such credit vouchers on your TAB hardware but, if needed, provide support and instructions to the final customer with the redemption procedure.

6. Liability

TAB shall not assume liability for contents and programmes downloaded from the TAB server, in particular for music titles or presentations with racist, pornographic or insulting content or for advertising pages created by clients.

As amended on 29.06.2015

End user license agreement for MICROSOFT software

IMPORTANT - READ CAREFULLY:

This End-User License Agreement ("EULA") is a legal agreement between you (either an individual or a single entity) and the manufacturer ("Manufacturer") or the special purpose computing device ("SYSTEM") you acquired which includes certain Microsoft software product(s) installed on the SYSTEM ("SOFTWARE PRODUCT" or "SOFTWARE"). The SOFTWARE includes computer software, the associated media, any printed materials, and any "online" or electronic documentation. By installing, copying or otherwise using the SOFTWARE, you agree to be bound by the terms of this EULA. If you do not agree to the terms of this EULA, Manufacturer and Microsoft Corporation ("Microsoft") are unwilling to license the SOFTWARE to you. In such event, you may not use or copy the SOFTWARE, and you should promptly contact Manufacturer for instructions on return of the unused product(s) for a refund.

SOFTWARE LICENSE

The SOFTWARE is protected by copyright laws and international copyright treaties, as well as other intellectual property laws and treaties. The SOFTWARE is licensed, not sold.

1. GRANT OF LICENSE: This EULA grants you the following rights:

- **Software:**

You may use the SOFTWARE as installed on the System.

- **Application Sharing:**

The SOFTWARE may contain technology that enables applications to be shared between two or more SYSTEMS, even if an application is installed on only one of the SYSTEMS. You should consult your application license agreement or contact the application licensor to determine whether sharing the application is permitted by its licensor.

- **Storage/Network Use:**

If the SOFTWARE PRODUCT is installed on the SYSTEM over an internal network from a server, you must acquire and dedicate a license for the SOFTWARE PRODUCT for each SYSTEM on which the SOFTWARE PRODUCT is used or to which it is distributed. A license for the SOFTWARE PRODUCT may not be shared or used concurrently on different SYSTEMS.

- **Back-up Copy:**

If MANUFACTURER has not included a copy of the SOFTWARE on separate media with the SYSTEM, you may make a single copy of the SOFTWARE for use solely for archival purposes with the SYSTEM.

2. DESCRIPTION OF OTHER RIGHTS AND LIMITATIONS

- **Limitation on Reverse Engineering, De-compilation and Disassembly:**

You may not reverse engineer, decompile, or disassemble the SOFTWARE, except and only to the extent that such activity is expressly permitted by applicable law notwithstanding this limitation.

- **Single SYSTEM:**

The SOFTWARE is licensed with the SYSTEM as a single integrated product. The SOFTWARE may only be used with the SYSTEM.

- **Rental:**

You may not rent or lease the SOFTWARE.

- **Software Transfer:**

You may permanently transfer all of your rights under this EULA only as part of a sale or transfer of the SYSTEM, provided you retain no copies, you transfer all of the SOFTWARE (including all component parts, the media, any upgrades or backup copies, and this EULA, and if applicable, the Certificate(s) of Authenticity), and the recipient agrees to the terms of this EULA. If the SOFTWARE is an upgrade, any transfer must include all prior versions of the SOFTWARE.

- **Termination:**

Without prejudice to any other rights, Manufacturer or Microsoft may terminate this EULA if you fail to comply with the terms and conditions of this EULA. In such event, you must destroy all copies of the SOFTWARE and all of its component parts.

- **Single EULA:**

The package for the SOFTWARE may contain multiple versions of this EULA, such as multiple translations and/or multiple media versions (e.g., in the user documentation and in the software). In this case, you are only licensed to use one (1) copy of the SOFTWARE PRODUCT.

3. UPGRADES AND RECOVERY MEDIA

- If the SOFTWARE is provided by Manufacturer on media separate from the SYSTEM and is labeled "For Upgrade Purposes Only" (Upgrade SOFTWARE), you may install one copy of the Upgrade SOFTWARE onto the SYSTEM as a replacement copy for the SOFTWARE originally installed on the SYSTEM and use it in accordance with Section 1 of this EULA. You may also install additional copies of the Upgrade SOFTWARE as replacement copies onto additional SYSTEMS which are the same brand and model as the SYSTEM and contain a duly licensed copy of the same version and language release of the SOFTWARE ("ADDITIONAL SYSTEMS"), provided that (1) Manufacturer has supplied a corresponding serialized sticker for each additional copy of the Upgrade SOFTWARE, and (2) you affix a serialized sticker per Manufacturer's instructions for each unit of Upgrade SOFTWARE you install.

- If the SOFTWARE is provided by Manufacturer on separate media and labeled as "Recovery Media", you may not make a copy of the SOFTWARE as described in Section 1 for archival purposes. Instead, you may use the Recovery Media solely to restore or reinstall the same version and language release of the SOFTWARE as originally installed on the SYSTEM and thereafter use the SOFTWARE as restored or reinstalled in accordance with Section 1 of this EULA. A single unit of Recovery Media may be used by you to restore or reinstall the SOFTWARE on ADDITIONAL SYSTEMS.

4. COPYRIGHT

- All title and copyrights in and to the SOFTWARE (including but not limited to any images, photographs, animations, video, audio, music, text and "applets," incorporated into the SOFTWARE), the accompanying printed materials, and any copies of the SOFTWARE, are owned by Microsoft or its suppliers. You may not copy the printed materials accompanying the SOFTWARE. All rights not specifically granted under this EULA are reserved by Microsoft.

5. PRODUCT SUPPORT

- Product support for the SOFTWARE is not provided by Microsoft or its subsidiaries. For product support, please refer to Manufacturer's support number provided in the documentation for the SYSTEM. Should you have any questions concerning this EULA, or if you desire to contact Manufacturer for any other reason, please refer to the address provided in the documentation for the SYSTEM.

6. LIMITED WARRANTY

- **Limited Warranty:** Manufacturer warrants that the SOFTWARE will perform substantially in accordance with the accompanying written materials for a period of ninety (90) days from the date of receipt. Any implied warranties on the SOFTWARE are limited to ninety (90) days. Some states/jurisdictions do not allow limitations on duration of an implied warranty, so the above limitation may not apply to you.
- **Customer Remedies:**
Manufacturer's and its suppliers' entire liability and your exclusive remedy shall be, at Manufacturer's option, either (a) return of the price paid, or (b) repair or replacement of the SOFTWARE that does not meet the above Limited Warranty and which is returned to Manufacturer with a copy of your receipt. This Limited Warranty is void if failure of the SOFTWARE has resulted from accident, abuse, or misapplication. Any replacement SOFTWARE will be warranted for the remainder of the original warranty period or thirty (30) days, whichever is longer.

- **No Other Warranties:**

Except as expressly provided in the limited warranty section above, the SOFTWARE is provided to the end user "as is" without of any kind, either expressed or implied, including, but not limited to, warranties of non-infringement, merchantability, and/or fitness for a particular purpose. The entire risk of the quality and performance of the SOFTWARE is with you.

- **No Liability for Consequential Damages:**

Manufacturer's suppliers shall not be held to any liability for any damages suffered or incurred by the end user (including, but not limited to, general, special, consequential or incidental damages including damages for loss of business profits interruption, loss of business information and the like), arising from or in connection with the delivery, use or performance of the SOFTWARE.

7. Note on JAVA Support.

The SOFTWARE product may contain support for programs written in JAVA. JAVA TECHNOLOGY is not fault tolerant and is not designed, manufactured, or intended for use or resale as ON-LINE CONTROL EQUIPMENT in hazardous environments requiring fail-safe performance, such as in the operation of nuclear facilities, aircraft navigation or communication systems, air traffic control, direct life support machines, or weapons systems, in which the failure of JAVA TECHNOLOGY could lead directly to death, personal injury, or severe physical or environmental damage

As amended on 12.11.2014

Warranty Terms

by TAB-AUSTRIA Industrie und Unterhaltungselektronik GmbH & Co KG
(TAB hereinafter)

We are granting a warranty for this machine under the following conditions:

1. Insofar as the "General Terms of Business of TAB-AUSTRIA Industrie- und Unterhaltungselektronik GmbH & Co KG" are not modified by the following, which sets out the conditions and scope of our warranty performance, these terms will continue to apply without change.
2. The warranty period for our products from delivery is:
 - **24 months** for (when purchased and operated in Austria)
 - Max Fire HD
 - Golden Island
 - Fun4Four Evo / Evo S
 - Fun4Four Mini
 - **12 months** for
 - all other products, particularly betting terminals
 - all products (including the above) purchased in Austria and operated outside Austria
 - **6 months** for
 - all spare partshowever, if a warranty period of more than six months still obtains for the machines, this period will apply in its entirety to the spare part.
3. The warranty will only be granted for new products by TAB, not for their spare parts, not for products of different brands and manufacturers and corresponding spare parts. No warranty is granted for used products either.
4. In accordance with the following provisions, we shall repair defects to the machine that have been demonstrably caused by a material and/or manufacturing fault which already existed at the time the product was handed over, and which was reported within 14 days of it becoming apparent to our sales partner or the first end user while still within the warranty period. No warranty is assumed for used machines.

5. The warranty exclusively covers such components that are essential to operating the product. It does not include easily damaged parts or wearing parts, such as, for example, glass, plastic or light bulbs. Minor deviations from the desired composition insignificant to the value and usability of the machine will not result in any warranty obligations. Damage caused by physical, chemical, electrical or electrochemical or other effects not related to the customary dedicated use will not result in any warranty obligations; neither does damage caused by water or abnormal environmental conditions or inappropriate operating conditions. Also, no warranty can be assumed for machine defects caused by transport damage for which we are not responsible, incorrect installation and assembly, incorrect use, non-observance of operating or assembly instructions or lack of care.
6. The warranty claim becomes void if repairs or interventions have been carried out by the customer himself/herself or by persons who were not accordingly authorized or who were not authorized by us or in the event of our machines being fitted with spare, supplementary or accessory parts that are not original parts, or if parts have been removed.
7. The warranty performance will be made in such a way that defective components will at our discretion be repaired or replaced with faultless components free of charge unless improvement or exchange are impossible or would result in for us unreasonable cost. In such cases, a reduction in price or, in the event of not only a minor defect, cancellation of sale may be claimed.
8. Machines for which a warranty performance is being claimed on the basis of this warranty must be handed over or sent to us. Repairs at the installation site are not possible. The customer will bear transport costs and the transport risk.
9. Exchanged parts will become our property.
10. Warranty performances will neither result in an extension of the warranty period nor will they initiate a new warranty period.
11. Further or other claims (in particular claims for damages suffered beyond the machine) are excluded insofar as liability is not mandatory by law.

12. These warranty terms apply to machines operated outside of Austria only insofar as they possess the technical requirements (e.g. voltage, frequency, etc.) for the corresponding country, have been officially approved for use there and are suited to the individual climate and environmental conditions.

13. The TFT LCD display consists of more than 1,000,000 Thin-Film Transistors (TFT). A small amount of missing, black, or luminous points is characteristic for TFT LCD technology. The warranty performance will be granted if more than 15 missing, black, or luminous points are present.

In case of any irregularities in the machine, please check power and all plug-in connections!

In case you cannot remove an error, please call our hotline:

Call +43-7229-780 40 – ext. 250

Notes



tab.at

TAB Austria

Industrie- und Unterhaltungselektronik GmbH & CoKG

Haider Strasse 40, 4052 Ansfelden, +43 (0)7229 78040

sales@tab.at, www.tab.at

facebook: TAB Austria, **youtube:** tabaustria, **linkedin:** tab-austria